



# **TSD 5000 Workshop Manual & Service Information Supplement**

## **Rolls-Royce Motor Cars**

Applicable to Rolls-Royce  
Flying Spur

Motor cars built from vehicle  
identification number (VIN)  
**\*SCAZG03C8SCX55012\***

TSD 5600

June 1994



**Printed and published by  
Rolls-Royce Motor Cars Limited  
Crewe  
Cheshire  
CW1 3PL  
England**

The information in this document is correct at the time of going to print but in view of the Company's continuing efforts to develop and improve its products it may have become out of date by the time you read it and you should, therefore, refer to publication TSD 4736 Product Support Information.

The information given here must not be taken as forming part of or establishing any contractual or other commitment by Rolls-Royce Motor Cars Limited and no warranty or representation concerning the information is given.

© Rolls-Royce Motor Cars Limited 1994



## Introduction

This supplementary manual is written specifically for skilled service personnel who should use the information in conjunction with Workshop Manual TSD 5000. When using this supplement it is assumed that the workshop safety and repair procedures generally accepted by the motor trade are appreciated, understood, and carried out.

Service personnel at Rolls-Royce Motor Cars Limited are always prepared to answer queries or give advice on individual servicing problems. When making an enquiry it is essential that the full vehicle identification number (VIN) is quoted.

This document is applicable to the Rolls-Royce Flying Spur from vehicle identification number \*SCAZG03CBSCX55012\*.



## Communications

All communication should be addressed to one of the following depending upon the car's domicile.

**Registered Office, Factory, and Service Centre**

Crewe Cheshire CW1 3PL England  
Telephone: 0270 255155 Administration  
Telephone: 0270 535000 Service reception  
Telex: 36121  
Fax: 0270 586548

**European Operations**

Crewe Cheshire CW1 3PL England  
Telephone: 0270 255155 Administration  
Telex: 36121  
Fax: 0270 586548

**Rolls-Royce Motor Cars International SA**

Au Glapin 1162 St-Prex  
Switzerland  
Telephone: 021 806 2731  
Telex: 454216  
Fax: 021 806 2729

**Rolls-Royce Motor Cars Inc.**

PO Box 476 Lyndhurst  
New Jersey 07071 USA  
Telephone: 201 460 9600  
Fax: 201 460 9392



# General information, Man hour schedules, and Parts list

Contents	Pages
Introduction	7
General information	7
Workshop safety	7
Engine	
Engine/transmission oil cooler – To remove and fit	7
Suspension	
Rear sub-frame mounts	9
Automatic ride control	9
Wheels and tyres	
Recommended tyres and tyre pressures	9
Man hour schedules	
Introduction	10
Man hour schedules (MHS) codes	10
Parts list	12



# Rolls-Royce Flying Spur

## Introduction

This information covers the removal and fitting procedures for the special features fitted to Rolls-Royce Flying Spur Motor Cars.

This information should be read in conjunction with the standard Rolls-Royce Silver Spur III, and

Bentley Turbo R procedures in TSD 5000 Workshop Manual, TSD 5506 Man Hour Schedules Manual, and TSD 5504 illustrated Parts List.

It should be noted that the number of special features fitted to these particular cars may vary depending on the specification.

## General information

Dimensions	
Wheelbase	3162 mm (124.50 in)
Overall length <i>Cars other than those conforming to a Canadian or USA specification</i>	5370 mm (211.42 in)
<i>Cars conforming to a Canadian or USA specification</i>	5379 mm (211.75 in)
Lubrication system	Dual engine/transmission oil cooler mounted forward of coolant radiator
Turbocharging system	Garrett AiResearch TO4B exhaust driven turbocharger. Boost pressure limited by a 'wastegate' in the exhaust system. Behr intercooler; lowers compressed air temperature
Final drive unit and drive-shafts	
Crown wheel teeth	41
Bevel pinion teeth	18
Final drive unit ratio	2.28:1
Top gear speed per 1000 rev/min	76,35 km/h (47.45 mile/h)
Overall gear ratios - Forward	5.65:1 3.37:1 2.28:1 1.71:1
Reverse	4.74:1
Final drive unit	Hypoid bevel
Wheels	
Size	7 $\frac{1}{2}$ J x 15
Type	Aluminium alloy
Tyres	255/65 R15 steel braced radial ply

## Workshop safety

In addition to carrying out the usual workshop safety precautions, note the following.

Never work beneath the car if it is only supported on a jack. Always ensure that car stands or blocks are used as a safety precaution.

If it is necessary to raise and support the complete car, reference **must be** made to the information given in Workshop Manual TSD 5000, Chapter A.

## Engine

**Engine/transmission oil cooler - To remove and fit**

1. Drive the car on to a ramp.
2. Select park position with the gear range selector lever. Switch off the ignition and remove the gearchange isolating fuse from the fuseboard.
3. Remove the front bumper (refer to Chapter S).
4. Disconnect the lower transmission pipe connections from either side of the oil cooler.

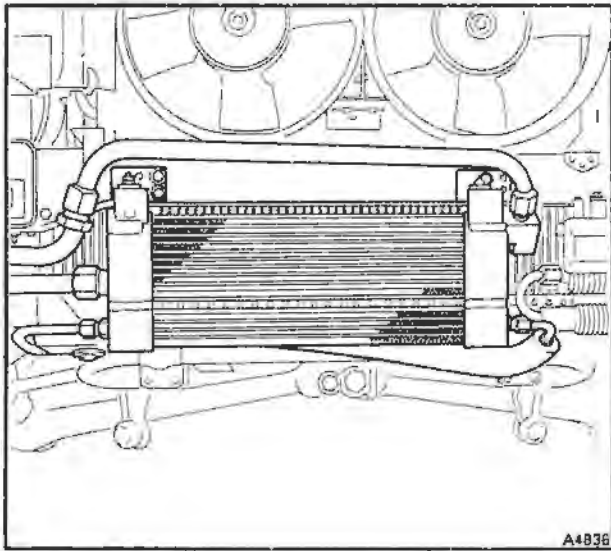
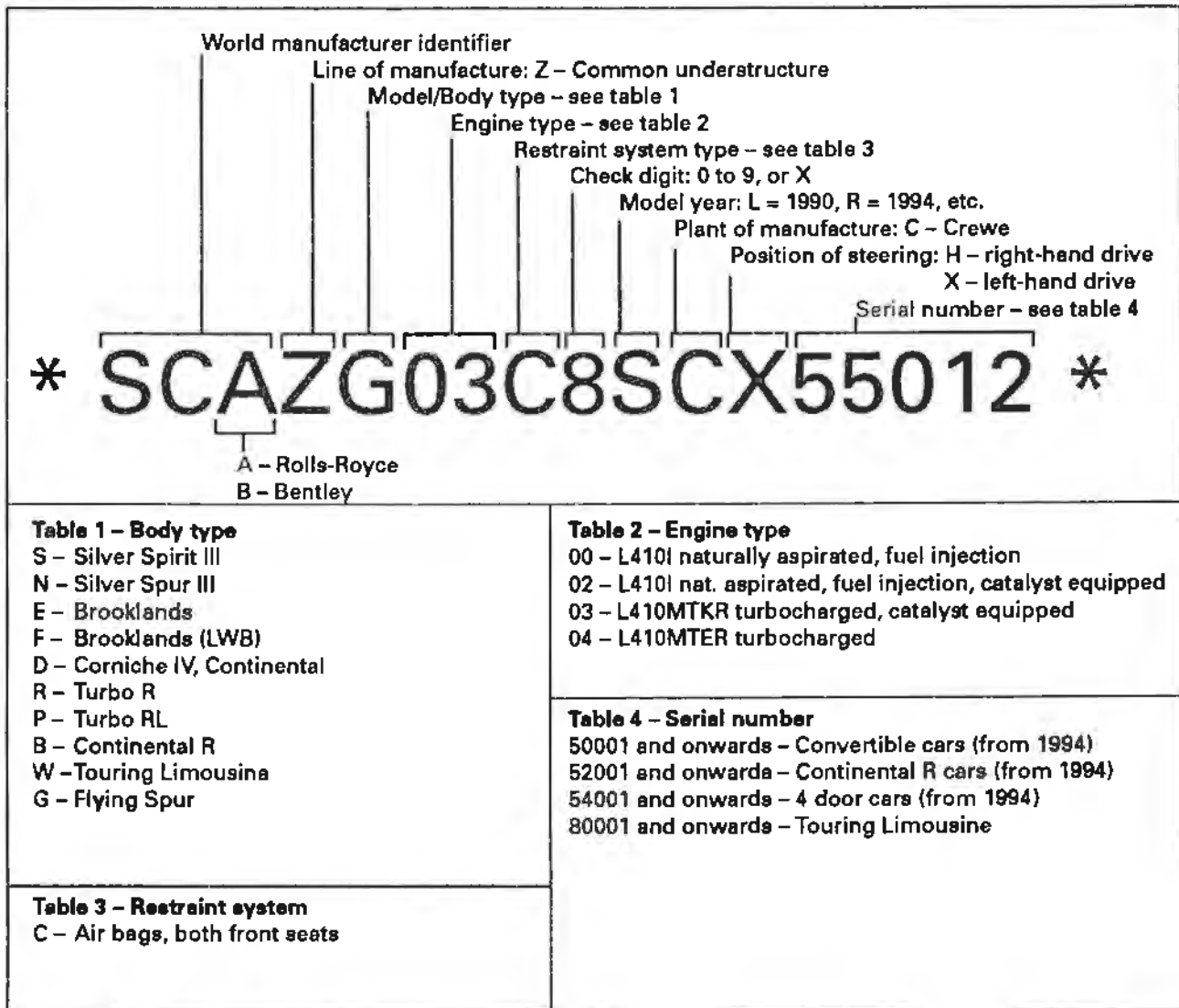

**Fig. 1 Engine/transmission oil cooler**

**Note** Ensure that the cooler union is always supported with a second spanner when either slackening or tightening the pipe nuts.

Ensure that a suitable container is available to collect any oil which may run out. Blank the open ports and pipes.

5. Disconnect the upper pipe unions from either side of the engine oil cooler. Blank the open ports and pipes. Discard the 'O' rings if damage/wear is evident.
6. Unscrew and remove the cooler mounting bolts to the crossmember. Lower the oil cooler from the car.
7. To fit the oil cooler, reverse the removal procedure, noting the following.
8. When fitting the cooler mounting bolts, check the mounting bushes and replace if necessary.
9. Examine the 'O' rings on the upper (engine) pipe connections and replace if necessary.
10. On completion, check the oil levels in the engine and transmission and top-up if necessary.



**Fig. 2 Vehicle identification number**

## Suspension

### Rear sub-frame mounts

Visually the mounts are identical to Rolls-Royce Silver Spur III but on Rolls-Royce Flying Spur the mounts have a unique rated rubber.

The mount type is identifiable by a paint spot marked on to the rubber of the mount.

Removal and fitting procedures of the rear sub-frame mounts are described in Workshop Manual TSD 5000, Chapter H.

### Automatic ride control

An electronically controlled automatic ride control system is incorporated in the suspension system of the Rolls-Royce Flying Spur.

The system operates by changing the damping rates of the front suspension dampers and the rear suspension struts. Three ride modes are available, comfort, normal, and firm, the correct setting being selected by an electronic control module.

The control module (CM) although visually identical to that fitted to Rolls-Royce Silver Spur III motor cars, is programmed to suit the individual nature of the Flying Spur ride/handling characteristics. The part number for the CM is situated above the diagnostic socket cover.

## Wheels and tyres

### Recommended tyres and tyre pressures

This section refers to the recommended tyres and tyre pressures for the Rolls-Royce Flying Spur.

Removal, balancing, and fitting procedures of wheel and tyre assemblies, are described in Workshop Manual TSD 5000, Chapter R.

Rolls-Royce Flying Spur motor cars are fitted with 7½ J x 15 aluminium alloy wheels.

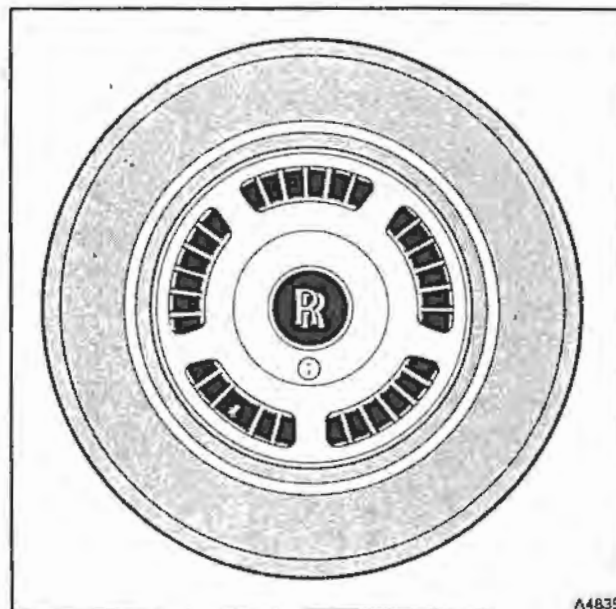

Fig. 3 Wheel/tyre assembly

To ensure the designed handling characteristics of the car are achieved, it is important to maintain the differential in tyre pressure between the front and rear wheels.

When checking tyre pressures ensure that the tyres are cold.

After checking the tyre pressures, ensure that the valve caps are fitted. The valve caps protect the valve from the ingress of water and provide a secondary air seal. Always ensure that a valve cap of the same metal as the valve stem is fitted. The fitting of a different metal cap will result in corrosion and prevent subsequent cap removal.

Tyre manufacturer /Construction	Size	Load/Speed rating	Sidewall markings	Loading conditions	Tyre pressures
Avon/Radial ply steel	255/65 R15	106V	Avon Turbospeed CR27 255/65 R15 106V	Up to four occupants and 22 kg (50 lb) of luggage	Speeds up to 160 km/h (100 mile/h) Front 1,80 bar (180 kPa, 26 lbf/in <sup>2</sup> ) Rear 2,30 bar (230 kPa, 33 lbf/in <sup>2</sup> ) Sustained speeds in excess of 160 km/h (100 mile/h) Front 2,10 bar (210 kPa, 30 lbf/in <sup>2</sup> ) Rear 2,55 bar (255 kPa, 37 lbf/in <sup>2</sup> )
				Up to maximum vehicle capacity weight	Speeds up to 160 km/h (100 mile/h) Front 1,80 bar (180 kPa, 26 lbf/in <sup>2</sup> ) Rear 2,55 bar (255 kPa, 37 lbf/in <sup>2</sup> ) Sustained speeds in excess of 160 km/h (100 mile/h) Front 2,10 bar (210 kPa, 30 lbf/in <sup>2</sup> ) Rear 2,80 bar (280 kPa, 40 lbf/in <sup>2</sup> )



## Man hour schedules

### Introduction

The following information is intended to supplement that contained within TSD 5506 Man Hour Schedule Manual in order to assist dealer personnel in obtaining repair times and for claiming warranty against Flying Spur motor cars.

The majority of MHS codes are as 1994 model year Silver Spur III and this should be used as the

starting point for obtaining a code. Where differences exist between the MHS codes for Flying Spur and Silver Spur III they are listed in the following table.

All this information is available on the 'Bulletin Board' screen facility available to dealers who have full access to the electronics links system.

### MHS codes

Code	Description	Repair	Time
09 . 01 . 35 . 00	Timing Cover	R	9.2
09 . 01 . 37 . 00	Gasket - Timing Cover	R	9.2
09 . 05 . 01 . 00	Cylinder Head	R	15.0
09 . 05 . 02 . 00	Cylinder Head Gasket	R	15.4
09 . 13 . 16 . 00	Flexplate/Flywheel	R	6.9
09 . 20 . 01 . 00	Turbocharger	R	4.9
09 . 20 . 16 . 00	Adaptor for Dump Valve Signal Pipe	R,T	S/T
09 . 28 . 03 . 00	Oil Filter Pedestal	R	9.0
09 . 31 . 01 . 00	Turbocharger Heatshield	A	S/T
09 . 31 . 01 . 00	Turbocharger Heatshield	R	0.5
09 . 31 . 03 . 00	Bolt	R,T	S/T
09 . 31 . 05 . 00	Turbocharger Oil Return Heatshield	A,R	S/T
09 . 35 . 17 . 00	Oil Feed Pipe - Crankcase to Turbocharger	A,V	S/T
09 . 35 . 18 . 00	Gasket	R,V	S/T
09 . 35 . 19 . 00	Retaining Bolt	R,T	S/T
09 . 35 . 21 . 00	Oil Drain Pipe - Turbocharger to Crankcase	R	S/T
09 . 35 . 22 . 00	Gasket	R	S/T
09 . 35 . 23 . 00	Retaining Bolt	R,T	S/T
31 . 54 . 01 . 00	Hose - Turbocharger to Boost Feed Pipe	R	S/T
31 . 54 . 02 . 00	Clip	R,T	S/T
31 . 54 . 05 . 00	Boost Feed Pipe	R	S/T
31 . 54 . 07 . 00	'O' Ring	R	S/T
31 . 54 . 09 . 00	Bolt	R,T	S/T
31 . 54 . 12 . 00	Dump Pipe	R	S/T
31 . 54 . 14 . 00	'O' Ring	R	S/T
31 . 54 . 15 . 00	Bolt	R,T	S/T
31 . 54 . 21 . 00	Hose	R	S/T
31 . 54 . 22 . 00	Clip	R,T	S/T
31 . 56 . 45 . 00	Vacuum Hose Dump Valve Solenoid	R	S/T
31 . 56 . 65 . 00	Banjo Connector - Transient Boost	R,T	S/T
31 . 56 . 68 . 00	Transient Boost Pipe	R	S/T
31 . 56 . 71 . 00	Clip	R,T	S/T
31 . 56 . 73 . 00	Hose - Pipe to Transient Boost Solenoid	R	S/T
31 . 56 . 76 . 00	Hose - Transient Boost Solenoid to T-Piece	R	S/T
31 . 56 . 78 . 00	T-Piece	R	S/T

**MHS codes (continued)**

<b>Code</b>	<b>Description</b>	<b>Repair</b>	<b>Time</b>
31 . 56 . 80 . 00	Hose T-Piece to Turbo	R	S/T
31 . 56 . 83 . 00	Hose – Boost Solenoid to T-Piece	R	S/T
31 . 57 . 01 . 00	Intercooler	R	S/T
31 . 57 . 02 . 00	Intake Hose	R	S/T
31 . 57 . 03 . 00	Clip	R,T	S/T
31 . 57 . 04 . 00	Mountings	A,R,T	S/T
31 . 57 . 05 . 00	Outlet Hose	R	S/T
31 . 57 . 06 . 00	Clip	R,T	S/T
31 . 57 . 07 . 00	Retainer	R,T	S/T
34 . 06 . 01 . 00	Volute Casing	R	6.7
34 . 06 . 02 . 00	Gasket	R	6.7
34 . 06 . 03 . 00	Seal Strip	R	6.7
37 . 06 . 01 . 00	Starter	R	2.0
37 . 10 . 01 . 00	Fuel Pump	R	0.7
37 . 11 . 22 . 00	Boost Control ECU	R	S/T
37 . 11 . 24 . 00	Boost Control Solenoid	R	S/T
37 . 11 . 27 . 00	Dump Valve	R	0.5
37 . 11 . 29 . 00	Dump Valve Solenoid	R	0.3
37 . 11 . 30 . 00	Transient Boost ECU	R	S/T
37 . 11 . 32 . 00	Transient Engine Loom	R	S/T
37 . 11 . 34 . 00	Transient Boost Solenoid	R	S/T
37 . 59 . 03 . 01	Front ABS Wheel Sensor	R,U	0.8
37 . 59 . 03 . 05	Rear ABS Wheel Sensor	R	1.4
43 . 02 . 00 . 00	Waste Gate	R	1.8
43 . 02 . 00 . 00	Waste Gate	U	3.4
43 . 02 . 06 . 00	Sealing Ring	R	S/T
43 . 02 . 07 . 00	Nut	T	S/T
43 . 03 . 02 . 00	Downtake	A	1.0
43 . 03 . 02 . 00	Downtake	R	3.2
43 . 03 . 02 . 00	Downtake	V	0.5
52 . 23 . 46 . 00	Wheeltrim	A,P,R	N/A
52 . 23 . 46 . 01	Painted Ring	R,U	N/A
52 . 23 . 46 . 02	Clip	R	N/A
52 . 23 . 46 . 08	Lock Cover	R	S/T
52 . 23 . 46 . 15	Wheel Trim Retaining Bolt	R,T	N/A
52 . 23 . 47 . 00	Rim Embellisher	R,U	N/A
52 . 23 . 47 . 01	Retaining Block	R,U	N/A
55 . 03 . 00 . 00	Transmission	K	14.0
55 . 03 . 00 . 00	Transmission	R	6.0
55 . 03 . 41 . 00	Torque Converter	R,U	6.3
55 . 03 . 46 . 00	Front Pump	R	6.8
55 . 03 . 47 . 00	'O' Ring Front Pump	R	6.8

**MHS codes (continued)**

Code	Description	Repair	Time
55 . 03 . 50 . 00	Lip Seal	R	7.0
55 . 07 . 13 . 00	Pipe – Oil Cooler Feed	R	2.0
55 . 07 . 14 . 00	Pipe – Oil Cooler Return	R	2.0

**Parts list****Introduction**

The following information is intended to supplement that contained within the illustrated parts list TSD 5504 in order to assist dealer personnel in obtaining parts for Flying Spur motor cars.

When using the parts list in relation to Flying Spur motor cars it should be remembered that

Engine/transmission parts will be found under the 1994 Bentley Turbo R listings.

The following table indicates those parts which are unique to Rolls-Royce Flying Spur, all other parts are to be found in TSD 5504 as listed under 1994 model year Silver Spur III.

Part number	Description	Quantity
* AHP 3028	Front RH Wing	1
UA 102/ZP	Bolt	4
UA 301/ZP	Nut	4
UA 1251/ZP	Washer	4
UB 72840	Stiffening Bar – Body Shell	1
UB 90538	Label, Tyre Selection	1
UB 90539	Nameplate – Flying Spur	1
UB 90541	Badge – Treadplate	1
UB 90542	Treadplate – Front LH	1
UB 90543	Treadplate – Front RH	1
UB 90544	Treadplate – Rear LH	1
UB 90545	Treadplate – Rear RH	1
UB 90738	Air Dam (Black)	1
UB 90942	Badge – Flying Spur	1
UB 90944	Badge Engine Cover	1
UD 72430	Label, Control Module	1
UD 75653	Transmission Control Module (TCM)	1
UD 75774	Automatic Ride Control Module (RCM)	1
UE 73820	Assy. Pipe Return Engine to Oil Cooler	1
UE 45371	Assy. Rubber Mounting Bracket to Oil Cooler	2
UM 20205	Washer, Mounting to Oil Cooler	4
UM 20706	Bolt, Bracket to Oil Cooler	4
UM 21443	Bolt, Mounting to Oil Cooler	2
UM 21557	Nut, Mounting to Oil Cooler	2
UM 22705	Washer, Bracket to Oil Cooler	4
UR 23318	Rear Subframe Mounts (Front)	2
UR 72430	Alloy Wheel	1
UR 73390	Assy. Hub Cap	1
UR 73455	Mounting Bracket Air Dam RH Side	1

Part number	Description	Quantity
UT 10488	Assy. Pipe Feed Transmission to Oil Cooler	1
UT 10489	Assy. Pipe Return Transmission to Oil Cooler	1
UT 10805	Dual Oil Cooler Engine/transmission	1
UT 10806	Pipe Return Engine to Oil Cooler	1
UT 10810	Protective Sleeve Feed Pipe	1
UT 10811	Protective Sleeve Return Pipe	1
UT 10875	Rear Subframe Mounts (Rear)	2
UT 11070	Bracket Oil Cooler	2
UT 11485	Assy. Pipe Feed Engine to Oil Cooler	1
PD 10212 A3	Assy. Rear Axle	1

**Note** \* When a front RH wing assembly is ordered for a Rolls-Royce Flying Spur, AHP 3028 will be supplied. This will require modifying by removing the portion shown in figure 4.

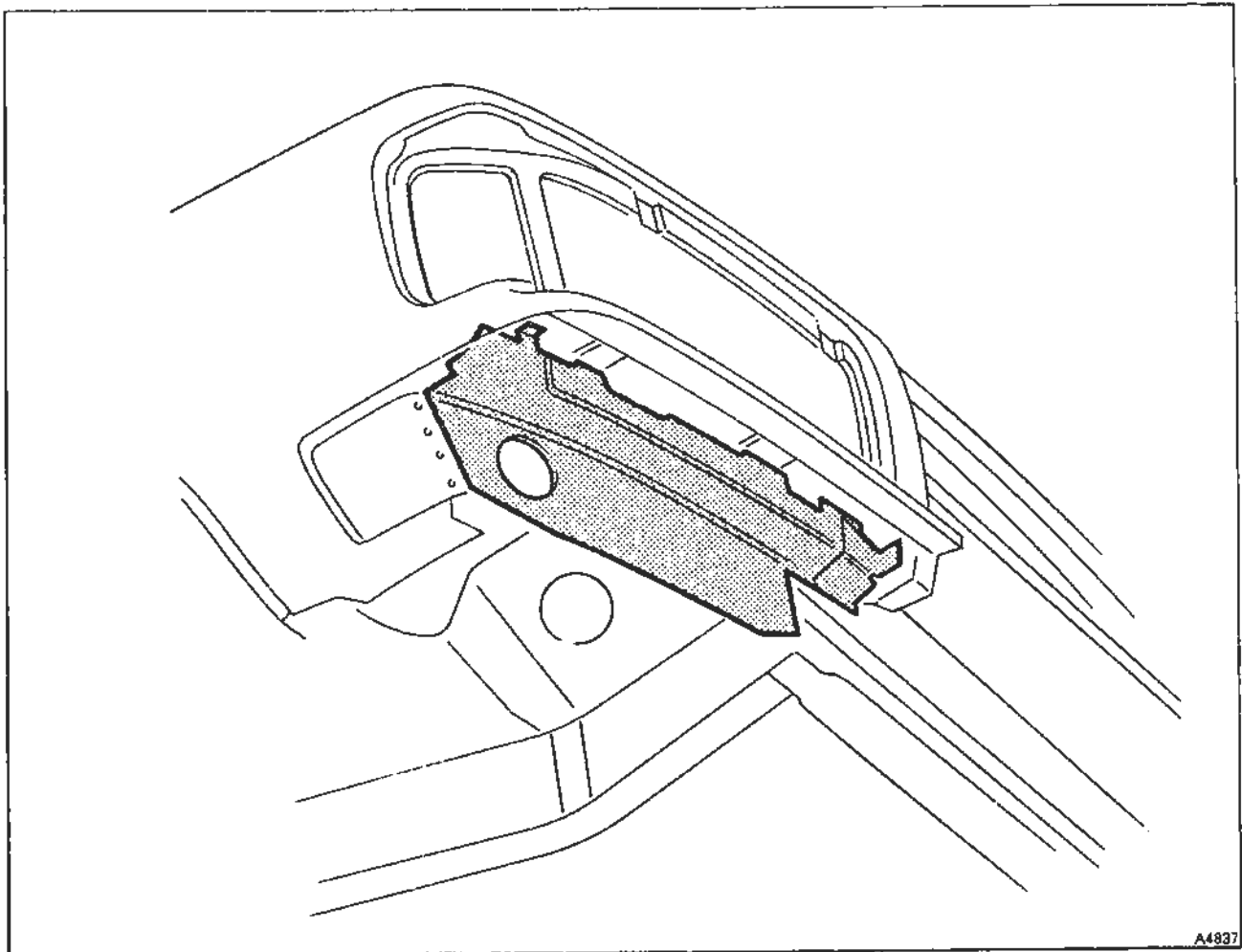

**Fig. 4 Front RH wing assembly**